

2012 International Conference on Future Electrical Power and Energy Systems

Dynamic Simulation Experimental Study on Biofouling Formation of Iron Bacteria in Heat Transfer Equipment

Guan Xiaohui¹, Liu Yang¹, Zhang Yanhui², Cao Shengxian²

¹Chemical Engineer Institute, Northeast Dianli University, Jilin, China

²School of Automation Engineering, Northeast Dianli University, Jilin, China

Abstract

In order to investigate the typical scale microbial Iron Bacteria of growth properties in circulating cooling water and water quality parameters factors on biofouling formation, this paper is purposed to deal with the slime which was obtained from the cooling tower bottom of circulating water, then a pure strain of Iron Bacteria was obtained through the separation, purification and enrichment culture. According to the morphological observation, as well as the physiological and biochemical indexes identification, the strain was identified as *Sphaerotilus*. The tubular heat exchanger dynamic simulation was used to study the biofouling formation with Iron Bacteria in circulating cooling water system. The experimental conditions were as follows: the water temperature 30 ± 0.2 °C, the flow rate 0.4m / s. This paper selected Iron ion concentration, COD_{Cr}, pH value, ORP, temperature and the total number of bacteria as the effect factors of biofouling formation, researching the link between Iron Bacteria, water quality parameters and biofouling formation. The results show that: the existence and content of iron bacteria results in directly increasing of fouling resistance; interacting among the parameters, and together determining the formation of biofouling.

© 2012 Published by Elsevier Ltd. Selection and/or peer-review under responsibility of Hainan University.

Open access under [CC BY-NC-ND license](https://creativecommons.org/licenses/by-nc-nd/4.0/).

Keywords: Circulating cooling water; Microbial fouling; Iron Bacteria; Water quality parameters; Dynamic simulation

1. introduction

Circulating cooling water accounts for 70% of water consumption in thermal power plant. At present, many thermal power plants use water reuse of sewage treatment as the supplementary water of circulating cooling water, so the cooling water system faces complex microbial scale formation and corrosion problems ^[1]. Biofouling are mainly composed of bacteria, such as Iron Bacteria, sulfate-reducing bacteria, slime forming bacteria, which are the main reason for growth of fouling resistance and flow resistance, and also one reason of the corrosion rate increase ^[2]. At present, there is a lot of work to study biofouling, and has made great achievements. Fornalik ^[3] used infrared spectroscopy to detect and analyze biofouling in the water pipe. Swee ^[4] showed that the initial stage of biofouling layer was the formation of biological gel because of attaching of the polysaccharide, which would further induced adhesion of proteins, polysaccharides and biological particles to form

adhesive attachments. Using fuzzy mathematics, Tianqing Liu ^[5] established evaluation and prediction model of the induction period of biofilm and the average amount of biofouling on the different materials surface.

This paper selected one of the typical scale microorganism-Iron Bacteria as the research object of dynamic simulation experiment in simulation of industrial operation environment. The Iron Bacteria was obtained from the cooling tower bottom of circulating water. Fouling resistance was on-line monitored by the dynamic simulation device. Fouling resistance measured and various water quality parameters detected in the same period were comparatively analyzed to investigate the link between various parameters and biofouling.

2. Materials and methods

2.1 Experiment instruments and materials

General dynamic simulation monitoring fouling resistance device (homemade), Orion 5-Star multi-parameter meter kits (USA), 721 spectrophotometer, pH / Cond 340i ORP meter, Stainless Steel ,etc.

2.2 Screening and identification of strain

The experimental strain is obtained from the cooling tower bottom of circulating water of a power plant, using methods GB/T14643.6-93^[6]. Experiments with liquid culture medium for: MgSO_4 0.5g/L, $(\text{NH}_4)_2\text{SO}_4$ 0.5g/L, K_2HPO_4 0.5g/L, CaCl_2 0.2g/L, NaNO_3 0.5g/L, $\text{C}_{12}\text{H}_{22}\text{FeN}_3\text{O}_{14}$ 10.0g/L ; Solid medium: based on the above liquid medium, adding in Agar powder 15.0g / L.

The Iron Bacteria is identified by the morphological observation, physiological and biochemical identification. The isolated iron bacteria is carried on Gram staining, observing morphology under a microscope, according to *Common bacteria system identification manual* ^[7] and *Berger bacteria identification manual* ^[8].

2.3 Dynamic experiment system

Dynamic simulation unit of cooling water biofouling resistance (DSUC) was designed according to the actual working conditions of cooling water system. Experimental device used the two same stainless steel pipes which were symmetrically arranged in the same water-bath. The experimental tubes with independent, unconnected experimental refrigerant loop were comparatively studied the effect between with Iron bacteria and without on the heat transfer characteristics of heat exchanger. The experimental set-up used for the fouling experiments is illustrated in Fig.1. Iron bacteria were added in the DSUC while the absorbance of strain reached to 0.5. Its dosage accounted for approximately 1% of the total water volume. The concentration of Fe^{2+} was 10mg/L to maintenance of essential nutrients for bacterial growth in the initial stage. The inlet and outlet temperature, wall temperature and flow of two loop were measured .Under experimental conditions - stainless steel tubes 12/16mm ,inlet water temperature: (30 ± 0.5) °C, temperature of water bath: (60 ± 0.5) °C, flow velocity: 0.4m/s to dynamic simulation convective heat transfer process of heat exchanger operating conditions. Fouling resistance was monitored on-line, and the water quality parameters were measured off-line in the same period.

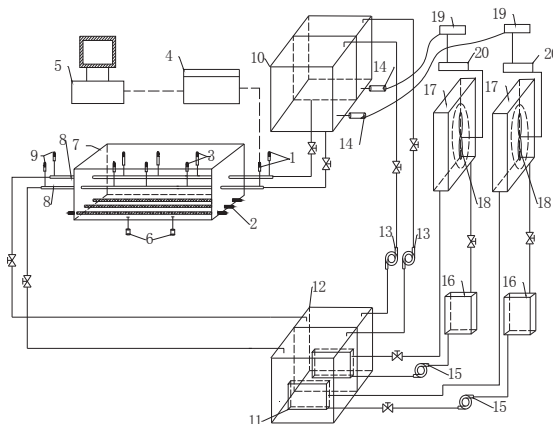

1- inlet temperature; 2- electric heater; 3- tubular wall temperature; 4- data acquisition card; 5- industrial control computer; 6- water bath temperature; 7- Constant temperature water bath; 8- stainless Steel tube; 9- outlet temperature; 10- upper tank; 11 -heat exchanger; 12- lower water tank; 13- circulating pump; 14- the water tank temperature; 15- motor of air-cooled radiator; 16- water tank of air-cooled radiator; 17- air filter; 18- air motor; 19- frequency converter; 20- PID controller;

Fig1. Dynamic simulation unit of cooling water biofouling resistance

2.4 Monitoring parameters and methods

Online testing parameters: biofouling resistance, input and output water temperature, flow velocity, pH value.

Offline analysis parameters: total number of bacteria, CODcr, ORP, Iron ion concentration.

Analysis of water quality parameters: referring to water and wastewater monitoring analysis methods [9] (Fourth Edition).

3. Results and Discussion

3.1 Screening and identification of strain

The slime was cultured in $29 \pm 1^\circ\text{C}$ after 14 days, black brown precipitate was produced and medium becomes from brown to transparent; when it was cultured in plate culture, on solid medium appeared the circular colonies of uniform distribution, the convex and black brown surface. So it was named T1. T1 was carried on identification of Gram staining and physiological – biochemical indexes and the result is that T1 is Gram negative bacteria. The result of physiological and biochemical indicators identified has been shown in Table1.

Table 1 The physiological and biochemical characteristic of strain T1

Detection indexes	Results
methyl red detection	+
citrate assimilation detection	+
cellulose assimilation detection	-
amylase assimilation detection	+
gelatin liquefaction detection	+
oxidase detection	+
catalase detection	+

According to Gram staining and physiological - biochemical identification, inspecting *Berger bacteria identification manual*, T1 strain is Iron Bacteria of *Sphaerotilus*.

3.2 Water quality on biofouling formation

1) pH value

The growth of Iron bacteria suitable pH range is 6.0-8.0, while the circulating cooling water pH value is generally 7.0-9.2, so the detection of pH is great significant to study biofouling induction period. The result of pH detection in the simulation process is shown in Figure.2. It can be seen from Figure. 2, pH value in Iron bacteria pipe increases larger in the initial stage, then the change tends to be steady. pH value in Iron bacteria pipe is lower than without Iron bacteria pipe because the microorganism produces CO_2 and other acidic metabolite, which can influence bacterial reproduction.

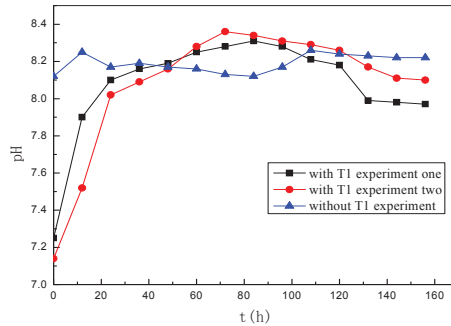

Fig. 2 pH curve with time

2) Iron ion

Because of the dissolved oxygen on stainless steel corrosion, a certain Fe^{2+} , Fe^{3+} and OH^- are produced in cooling water. The resultant will do the Brownian motion in the form of gelatinous ferric hydroxide in water, and they will condense each other to deposit on metal surfaces. That led to the under-deposit corrosion. The change of iron content in the simulation experiment is shown in Figure.3. The experimental system is open, so oxygen content is enough. Fe^{2+} will be partially oxidized to Fe^{3+} to form $\text{Fe}(\text{OH})_3$ precipitation. So the bacteria are added or not, Fe^{2+} concentration will decrease. After adding in Iron bacteria, it will oxidize Fe^{2+} to $\text{Fe}_2\text{O}_3 \cdot \text{mH}_2\text{O}$ and a lot of slime is formed around the bacteria^[10]. Fe^{2+} concentration decline tendency of adding bacteria loop is significantly higher than without bacteria loop. It can be shown in Figure.3, Fe^{2+} content is close to 0, Iron bacteria stop multiplying, and tube wall slime does not change after 90 hours. This matches with the fouling resistance curve in Figure .6 in time, and that shows tube wall slime is the main factor of fouling resistance changes.

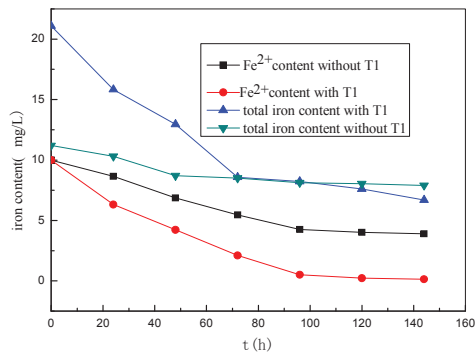

Fig. 3 Iron content curve with time

3) CODcr

Nutrient of the cooling water is usually from added water, air and equipment leaks, COD is an indicator of nutrient penetration level. The actual operation shows that the failure caused Bio-fouling likely occur

when COD of circulating cooling water is more than 14mg/L. CODcr of simulation experiment detection result is shown in Figure.4. It is told that in Figure. 4, content of the system CODcr declines rapidly in initial system operation, that because large of growth and reproduction of adding strains T1 which consumes nitrogen source and carbon source; after running for 80 hours, its content keeps constantly. The reason is that the adding nutrient can meet the minimum conditions of microorganism growth. Some time later, as lack of nutrient source, microbial growth is limited, and a large number of bacteria will die, which causes CODcr to maintain stably. That the COD of the experimental pipe with bacteria is more than that without bacteria is due to metabolites of T1.

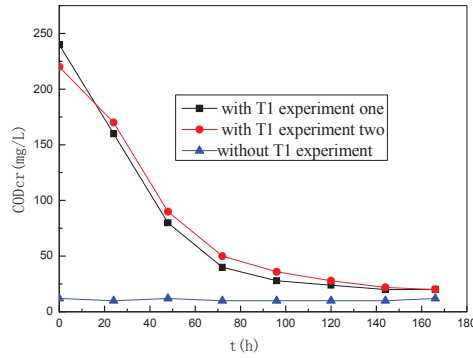

Fig. 4 CODcr curves with time

4) ORP

ORP is a comprehensive index of reflection water. It is not clear to demonstrate the concentration of some kind of oxygen substances and reducing substances, but there may be an indirect understanding material types and content of oxidation and reduction in water. It can reflect the water quality status. The growth process of microorganism can not change the ORP of the surrounding environment, but its metabolites are reducing organic substance which can reduce ORP. Experimental result is shown in Figure. 5: When T1 is not added in the simulation system, ORP value fluctuates between 275 and 295mv. After adding T1, the average ORP value is much lower than without bacteria, which indicates that T1 in the experimental system produced reductive organic compounds.

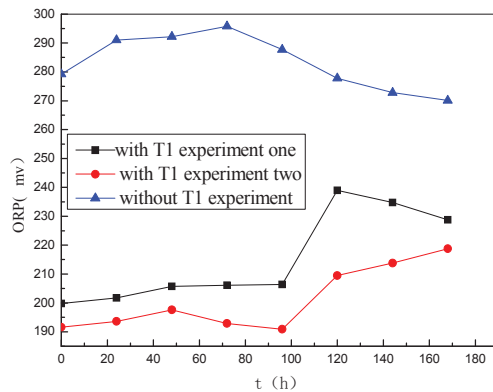

Fig. 5 ORP curves with time

3.3 Dynamic simulation analysis of the T1 biofouling formation

1) Fouling resistance

The experimental results of fouling resistance in dynamic simulation experiment have been shown in Figure. 6. The comparative results between the stainless steel tube with the bacteria T1 and another tube without T1 have been shown in Figure. 7. As shown in Figure. 6, the process of microbial growth can be divided into 3 phases. The biofilm grows slowly in the 1st phase, which also can be called the initial phase. In the 2nd phase, the microorganisms begin to deposit, and the thickness of biofilm increases in exponential growth. The biofilm thickness is not any more to grow, and the biofouling resistance would reach to the stable value in the 3rd phase, which also can be called the adsorption-desorption smooth phase.

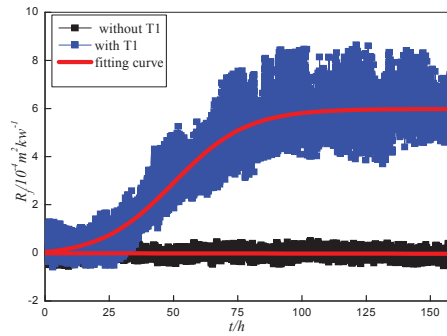

Fig .6 Fouling resistance curve

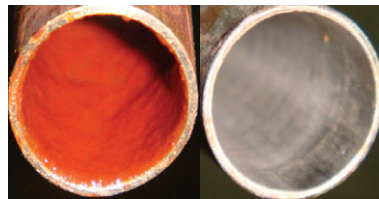

Fig. 7 Fouling on the tube wall of the stainless steel (Left with T1, Right without T1)

2) Total number of bacteria

The total number of bacteria is shown in Table 2. As shown in Figure.6, Figure.7 and Table 2, to the loop with the bacteria T1, the beginning phase, also can be named the fouling induction is about 25 hours when T1 is added to the experimental loop. Later the number of the bacteria T1 increases significantly in this loop, and the fouling resistance began to rise. After about 50 hours, the fouling resistance would reach the stable value which changes in a certain range. When the experiment is finished, a layer of fouling could be seen, which adheres onto the wall of the stainless steel tube. The total number of bacteria T1 could be detected out and reach to 5.1×10^6 cfu/ml. In contrast with the loop with T1, the microbial colonies had no change in another loop without T1, and the fouling resistance increased a little. There are no bacteria in the stainless steel tube of without T1. The added value of the resistance is caused by the deposition of insoluble particulate matter. So T1 is the main reason of causing the resistance adding, and induces the formation of biofouling on the tubular wall of the stainless steel.

Table 2 Changes in total number of bacteria (cfu/ml)

running time	1st day	3rd day	5th day	7th day	the slime of end
with T1 pipeline	4.1×10^8	3.4×10^8	6×10^7	6.3×10^6	5.1×10^6
without T1 pipeline	3.2×10^3	3.6×10^3	5×10^3	3.2×10^3	nothing

4. Conclusions

(1) Iron Bacteria T1 of *Sphaerotilus* was isolated from Changchun a power plant cooling tower bottom of circulating water, which has the characteristics of the biofouling scale, can form biofouling in the exchanger surface of stainless steel tubular heat transfer, and its fouling induction period is 25 hours on stainless steel.

(2) Through the results analyzed by the dynamic simulation of the biofouling formation, the fouling resistance of the tube with the bacteria T1 can reach $6.81 \times 10^{-4} \text{ m}^2 \cdot \text{k/w}$, but the tube without T1 can only reach $4.85 \times 10^{-5} \text{ m}^2 \cdot \text{k/w}$. It shows that the existence and content of iron bacteria is one direct reason of that which can cause the resistance to add; The detecting results of water quality parameters show that the content of Fe^{2+} can determine the amount of iron bacteria, thereby would affect the amount of slime on the wall. Because the reproduction and metabolism of Iron bacteria are closely related to pH、COD、ORP, so this factors can finally impact the formation of biofouling.

Acknowledgment

Project Subsidized by National Natural Science Foundation of China (No.50806010), the Special Funds for Major State Basic Research Projects of China (No.2007CB206904), Science and Technology Development Projects of Jilin Province (No. 20100432).

Reference

- [1] Yang Shanrang, Xu Zhiming, Sun Lingfang. Fouling and countermeasures of heat transfer equipment[M]. (2rd Edition), Beijing: Science Press.2004
- [2] Yu Dayu, Men Hong, Mu Shengwei, Yang Shanrang. The characteristics of biofouling detection technology, current situation and development trend. Microbiology bulletin, 2008; 35(12): 1955-1960
- [3] Mark Fornalik, STS Ethox. Early, Direct Detection of Biofilms and CIP-Related Problems in Liquid Process Systems[C]. Northeast IFT Food Industry, 2009
- [4] Swee Loong Khordeng, Darren Delai Sun, et al. Biofouling development and rejection enhancement in long SRT MF membrane bioreactor [J]. Process Biochemistry 2007, 42(12):1641-1648
- [5] Liu Tianqing, Yu Ruihong, et al. Material surface properties on the effect of the comprehensive evaluation and prediction of biofouling formation [J]. Journal of environmental science, 2001, 21(4): 491-495
- [6] National standards of the People's Republic of China GB/T 14643.6-93. Industrial circulating cooling water Determination of iron bacteria. Approved by the State Bureau of Technical Supervision 1993-08-06
- [7] Dong Xiuzhu, Cai Miaoying, et al. Common bacteria system identification manual. Beijing: Science Press, 2001, 62-65
- [8] Buchanan, Gibbons, et al. Berger bacteria identification manual. (Eighth Edition). Science Press, 1984
- [9] Water and wastewater monitoring and analysis methods (4th Edition). Beijing: National Environment Science Press, 2003, 201-271
- [10] Zhou Baiqing, Chen Zhihe, et al. Thermal power plant water treatment (4th Edition). China Electric Power Press, 2009, 465